

INSTRUCTION MANUAL

NSW Schools / TAFE - MC-315CE
44rpm Cold Saw (240V)
110 x 85mm



K8271



Established 1930
Distributors of new & used workshop Equipment

S836

**MC-315F COLDSAW
INSTRUCTION & PARTS**

MANUAL

28-03-2003

S836 MC315F 28/3/03

OPERATION INSTRUCTION FOR MC-315F

CIRCULAR COLD SAWING MACHINE



SOCO

SOCO MACHINERY CO., LTD.

7, 14th Road, Taichung Industrial Park,
Taichung, Taiwan, R.O.C.

TEL: 886-4-3591888

FAX: 886-4-3592386

<http://www.soco.com.tw>

E-mail: socomc@seed.net.tw

CONTENTS

1. SAFETY PRECAUTION-----	3
2. SPECIFICATIONS AND OUTLINE DRAWING-----	4
2.1 Technical Data	
2.2 Cutting Capacity	
2.3 Accessory	
2.4 Outline Description	
3. INSTRUCTION OF INSTALLATION-----	8
3.1 Unpacking and Inspection	
3.2 Lifting, Moving and Anchoring	
3.3 Connecting Electric Power	
3.4 Filling coolant	
3.5 Procedure to install the stopper	
4. FUNCTION OF CONTROL DEVICES-----	10
5. INSTRUCTION OF OPERATION-----	11
5.1 Preparation for Operation	
5.1.1 Adjustment of Clamping Vise	
5.1.2 Installation of Saw Blade	
5.1.3 Adjustment of Saw Blade Low Stop Position	
5.1.4 Adjustment of Saw Blade Rotating Speed	
5.1.5 Adjustment of Miter Cutting	
5.2 Steps of Operation	
5.3 Daily Inspection and Maintenance	
6. ELECTRICAL SYSTEM DIAGRAM-----	13
7. PARTS DRAWING AND LIST-----	14

1. SAFETY PRECAUTION

- (1) Operator of the machine shall read the operation instruction carefully and understand the safety requirement and the function of all parts of machine thoroughly.
- (2) Only the authorized and dedicated operators are allowed to operate the machine.
- (3) The machine is designed and manufactured to meet the applicable safety regulation of your country. Please do not remove or modify any safety device or parts, such as safety cover and guard of saw blade, emergency stop button, etc.
- (4) Assure the correct electric power, such as capacity of voltage, amperage and protection, is connected to the machine before operation.
- (5) Please wear a pair of goggles when operating the machine.
- (6) Please push the emergency stop button and turn off the main switch immediately when any malfunction or emergency situation should occur.
- (7) Please disconnect the electric power when install, maintain, repair or disassemble the machine.
- (8) Please pay extreme attention to adjust or exam the machine with electric power has been connected.
- (9) Please operate the machine in a bright and clean environment
- (10) Please clean and maintain the machine periodically to assure the machine running in proper condition.
- (11) Do not operate the machine excess its allowable condition.

2. SPECIFICATIONS AND OUTLINE DRAWING

2.1 Technical Data

MC-315F TECHNICAL DATA		
	A-TYPE	B-TYPE
MAIN MOTOR	2/1.4 HP, 2/4 POLE	1.4/1 HP, 4/8 POLE
ARBOR RPM (60 HZ)	100/50	50/25
SAW BLADE TYPE	HIGH SPEED STEEL BLADE	
SAW BLADE SIZE	OD: 250/300/315/325 mm	
COOLING PUMP	1/8 HP	
AIR PRESSURE	--	
WEIGHT	200 KG	

2.2 Cutting Capacity

MC-315F CUTTING CAPACITY(USE ϕ 315 BLADE) mm		
FOR MILD STEEL	CUTTING ANGLE	
	90°	45°
ROUND TUBE	ϕ 95	ϕ 95
SQUARE TUBE	85×85	80×80
ANGLE	85×85	80×80
RECTANGLE	80×110	80×80
SOLID ROUND TUBE	ϕ 55	ϕ 45
SOLID SQUARE TUBE	50x50	40x40
MC-315F CUTTING CAPACITY(USE ϕ 325 BLADE) mm		
FOR MILD STEEL	CUTTING ANGLE	
	90°	45°
ROUND TUBE	ϕ 100	ϕ 100
SQUARE TUBE	90×90	85×85
ANGLE	90×90	85×85
RECTANGLE	85×110	85×85
SOLID ROUND TUBE	ϕ 55	ϕ 45
SOLID SQUARE TUBE	50x50	40x40

2.4 Outline Description

(1) Front View

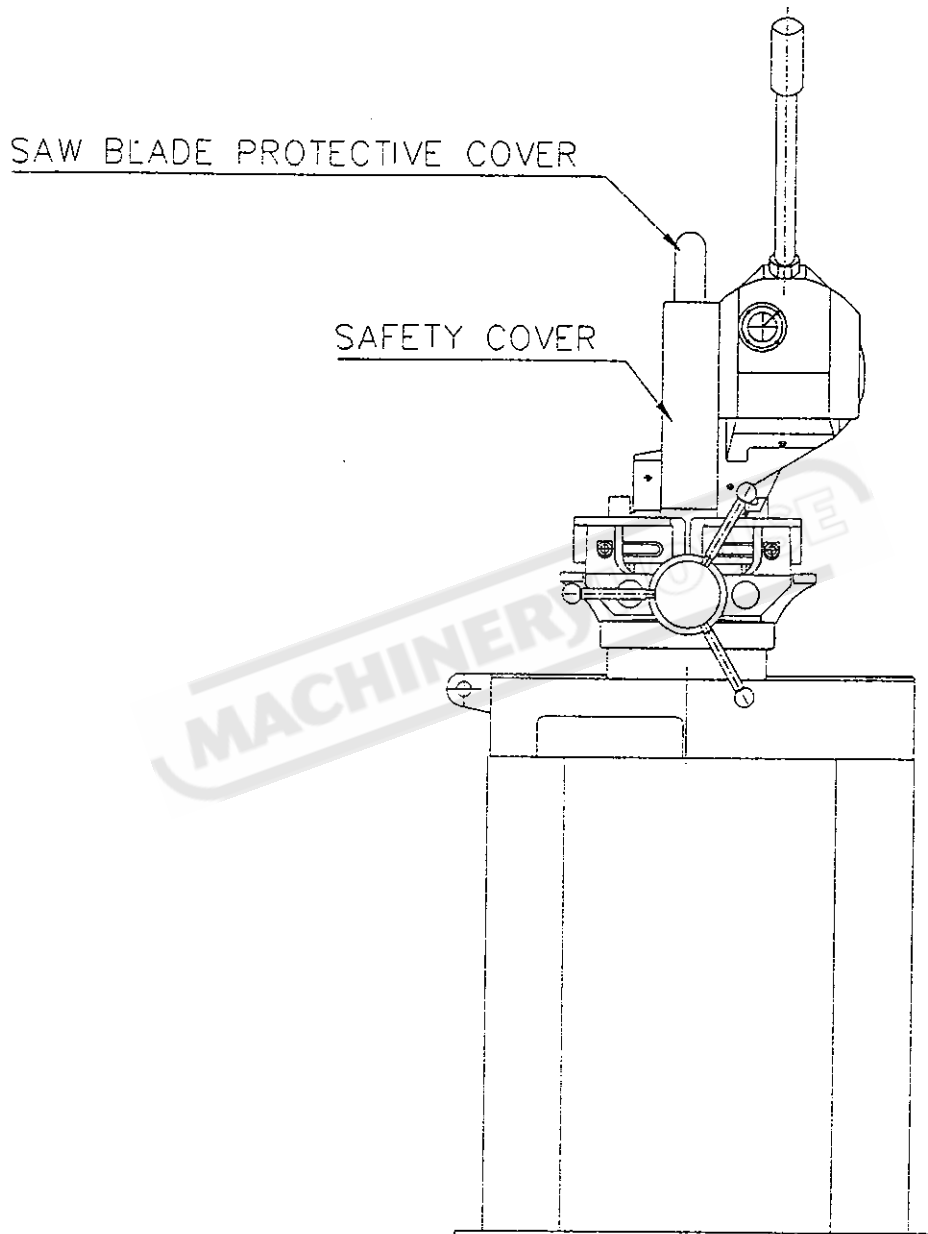

FRONT VIEW
OF
MC-315F

(2) Right Side View

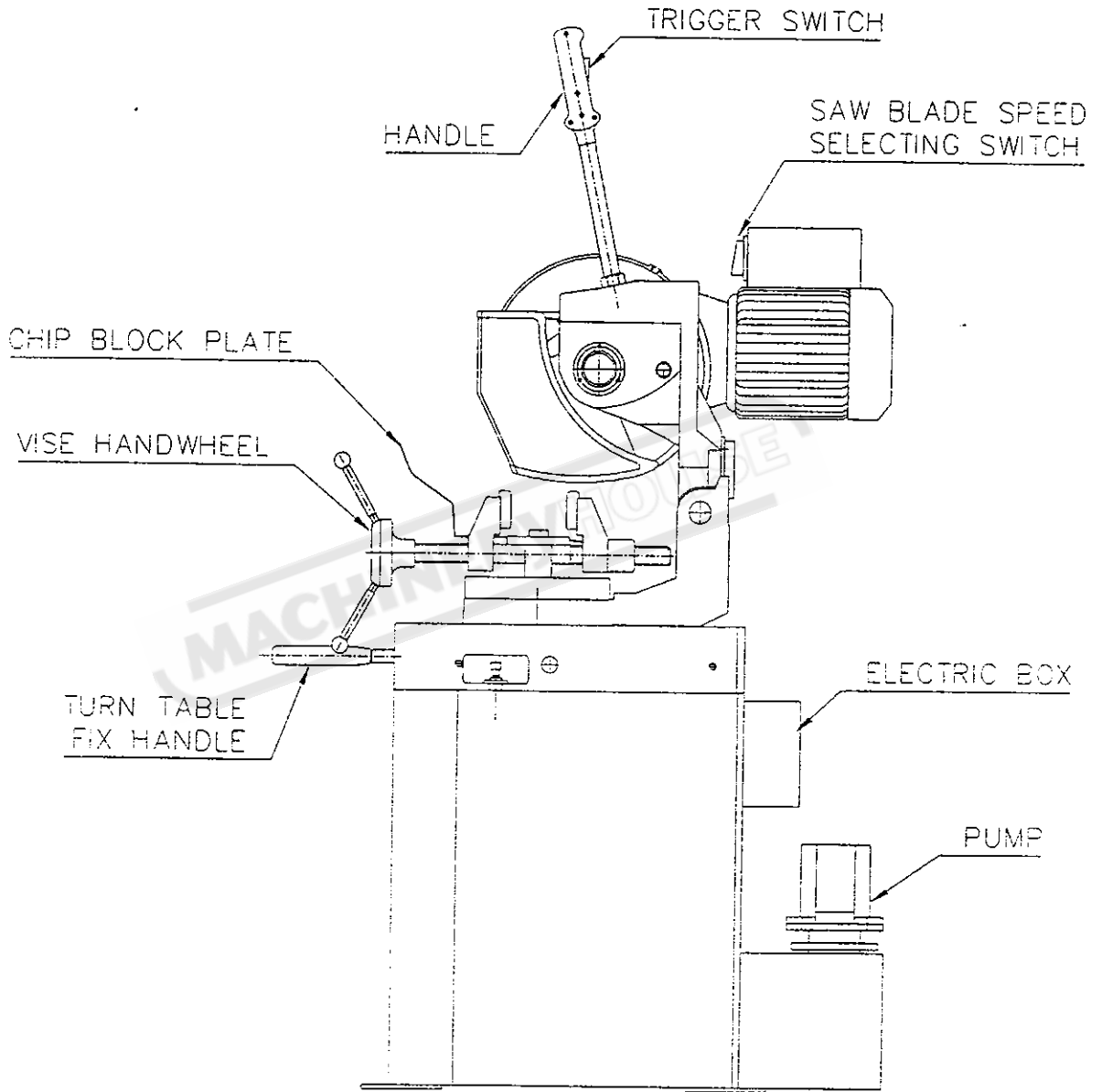

RIGHT SIDE VIEW
OF
MC-315F

(3) Left Side View

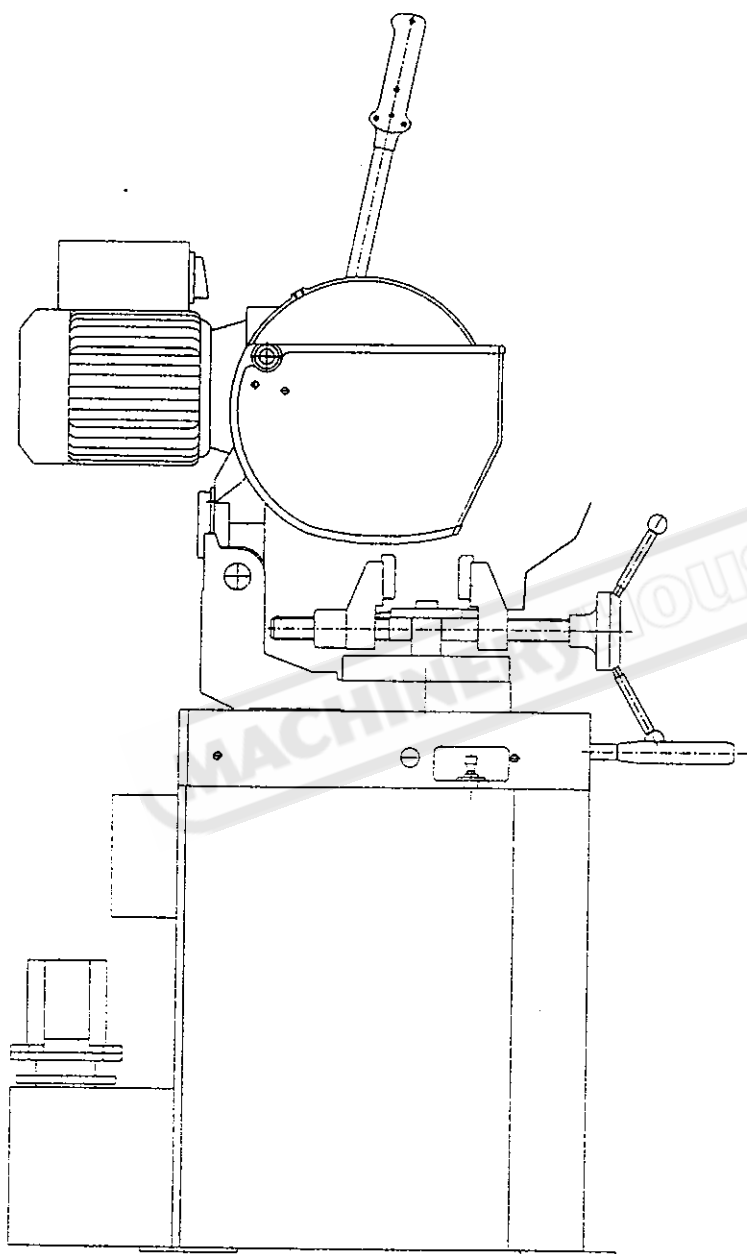

LEFT SIDE VIEW
OF
MC-315F

3. INSTRUCTION OF INSTALLATION

Note: Please read the instruction carefully before installation.

If having any question please contact your dealer for prompt service.

3.1 Unpacking and Inspection

- (1) Check if there is any damage on the wooden case or the plastic bag that used to pack the machine. Should any damage be found on the machine, please claim for the damage against the delivery or insurance company.
- (2) Check the machine and accessories against the packing list. Should any shortage, please contact your dealer.

3.2 Lifting, Moving and Anchoring

- (1) Lifting eyebolts have been mounted on the machine. Please use hoist and sling devices with enough capacity to lift and move the machine.
- (2) Slots, designed at the bottom of the machine, can be used by forklift to move the machine.
- (3) Please watch over the obstacle or personnel that may be on the way of moving the machine.
- (4) Place the machine on a horizontal foundation. Use anchor bolt and nut to fix the machine.

3.3 Connecting Electric Power

Note:

- (1) Assure the main power switch is at "OFF" position and the saw blade motor speed select switch is at "OFF" position before connecting the machine to electric power source
 - (2) Do not install saw blade on the main shaft when checking the rotational direction of the main shaft.
-
- (1) Only qualified electrician can connect electric power.
 - (2) The voltage, amperage and protection capacity of the power source shall meet the requirement of the machine.

- (3) Check the rotation of the saw blade shaft (arbor). Change over two conductors in junction box if the direction of rotation does not consist with the direction of the label on the saw blade safety cover.

3.4 Filling coolant

- (1) Pour the diluted sawing oil on the table of the machine. The solution will flow into the coolant tank.
- (2) The dilute ratio (water: oil) is 5:1 for hard or high alloy steel and 10:1 for mild steel.

3.5 Procedure to instll the stopper

- (1) Mount the stopper arm at the "0" point on the stopper support beam as illustrated on following figure1.
- (2) Put the stopper support beam into the hole in the base plate.
- (3) Fix the stopper support beam when the stopper is just touching the sawblade as illustrated on following figure2.

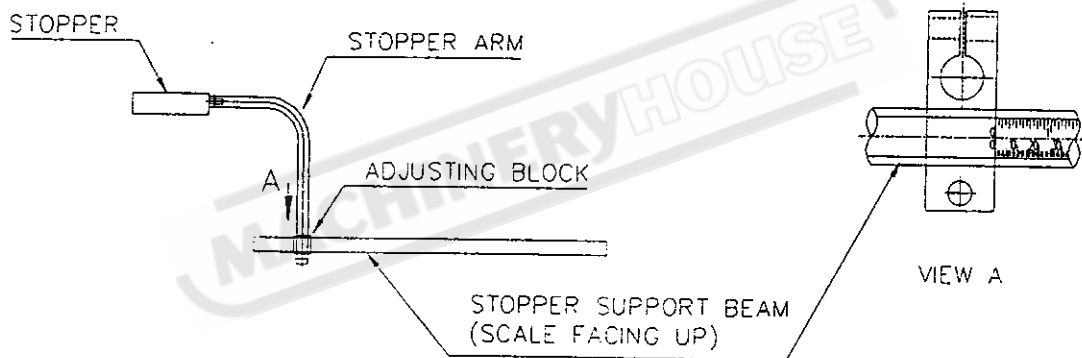

FIGURE 1

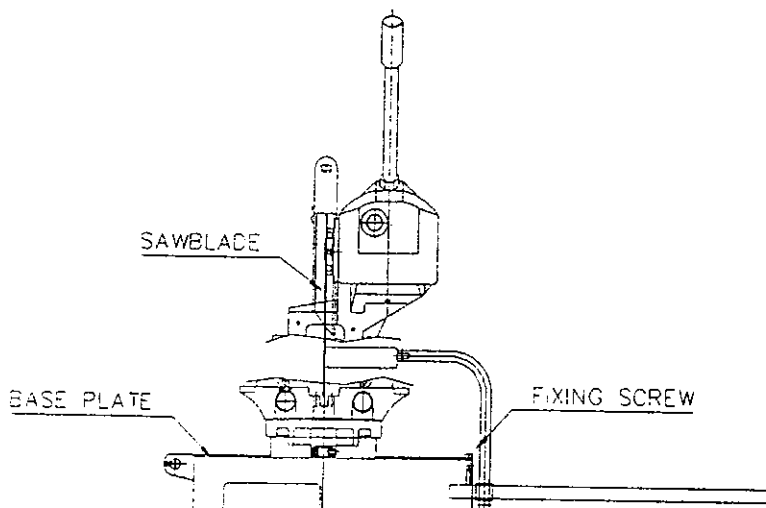

FIGURE 2

4. FUNCTION OF CONTROL SWITCHES

(1) Trigger Switch

This is an "ON-OFF" two-position trigger switch on the handle to connect or disconnect power to the machine. The main (saw blade) motor and coolant motor run when this switch is pressed. The above motors stop when this switch is released.

(2) Saw Blade Motor Speed Select Switch

This is a "LOW-OFF-HI" three-position level switch on the top of motor for selecting a suitable speed for the saw blade to cut material.

MACHINERYHOUSE

5. INSTRUCTION OF OPERATION

5.1 Preparation for Operation

5.1.1 Adjustment of the Clamping Vise

- (1) Release the handle.
(Cutting head shall be at up position)
(Saw blade motor shall stop.)
- (2) Turn the vise hand wheel counter-clockwise to open the vise.
- (3) Put a work piece into the clamping area of vises.
- (4) Turn the vise hand wheel clockwise to close the vise and fasten a work piece.
- (5) Turn the vise hand wheel 1/2 (half) turn counter-clockwise to open the vise slightly.
This is the ready position to take in or remove a work piece.

5.1.2 Installation of the Saw Blade

- (1) Release the handle.
- (2) Turn off the saw blade motor speed select switch.
- (3) Open saw blade safety cover.
- (4) Remove the clamping flange from the saw arbor.
- (5) Clean the clamping surfaces of flange and arbor free from any dirt or chips.
- (6) Clean the clamping area of the saw blade.
- (7) Mount saw blade on the arbor. Align the pinholes of saw blade and arbor. Put the clamping flange on the saw blade, and tighten the center bolt.
Note: The rotation of saw blade shall be **counter-clockwise** while looking at the mounting surface. There is a directional mark labeled on the protection cover.
- (8) When lock the center bolt, **keep the front part of saw blade downward** to eliminate the gap between pin and pinhole.
- (9) Close the saw blade safety cover.

Note: The following Charts of " Number of Saw Blade Tooth Selection " are for reference.

Number of Saw Blade Tooth (T) for Mild Steel Solid Bar Cutting					
Wall Thickness of Tube (mm)	Diameter of Saw Blade (mm)				Remark
	Φ250	Φ275	Φ300	Φ350	
0.6~0.8	T=280	280	300	320	For Tube

0.8~1.0	240	280	280	320	Diameter D ≥ 10 mm
1.0~1.2	220	240	240	280	
1.2~1.6	200	220	240	240	
1.6~2.0	180	200	220	220	
2.0~2.5	150	180	180	200	D ≥ 15 mm
2.5~3.5	120	150	150	180	D ≥ 20 mm
3.5~4.5	90	120	120	150	D ≥ 25 mm
4.5~5.5	80	80	90	120	D ≥ 30 mm
5.5~7.0	64	64	80	90	D ≥ 40 mm

For Wall Thickness ≥ 2 mm, the Formula for Number of Tooth T is as following

$$T = 2 \times (\text{Diameter of Saw Blade} \times 3.14) \div (\text{Wall Thickness of Tube})$$

Number of Saw Blade Tooth (T) for Mild Steel Solid Bar Cutting					
Size of Bar (mm)	Diameter of Saw Blade (mm)				
	Φ250	Φ275	Φ300	Φ350	
6~10	T=180	200	200	220	
10~14	160	160	180	200	
14~18	150	160	160	180	
18~22	120	150	150	160	
22~28	90	90	120	160	
28~35	80	80	90	120	
35~45	70	70	80	90	
45~50	64	64	70	80	

For Size of Bar ≥ 38 mm, the Formula for Number of Tooth T is as following

$$T = 4 \times (\text{Diameter of Saw Blade} \times 3.14) \div (\text{Size of Bar})$$

1. For stainless steel, the number of tooth is one grade more than mild steel.
2. For aluminum and copper, the number of tooth is one grade less than mild steel.
3. For 45° miter cutting, the number of tooth is one grade less than 90° cutting.

5.1.3 Adjustment of the Saw blade Low Stop Position

- (1) Pull down the handle to the position that the saw blade just breaks through the work piece.
- (2) Adjust the bolt and lock nut that is under the saw head to just stop the saw head going down.

5.1.4 Adjustment of the Saw Blade Rotating Speed

Turn the saw blade speed-selecting switch to one of "LOW", "HI" or "OFF" position.

5.1.5 Adjustment of the Miter Cutting

- (1) Push the turning table fixing handle leftward.
- (2) Turn the turning table to the required angle.
- (3) Push the fixing handle rightward.

5.2 Steps of Operation

- (1) Prepare the machine as states in Section 5.1.
 - (2) Put a work piece into vise.
 - (3) Turn the vise hand wheel clockwise to clamp the work piece.
 - (5) Pull down the handle and press trigger switch.
 - (6) The saw blade starts rotating. The coolant starts flowing out of nozzle.
 - (7) Continue to pull down the handle until the saw blade cuts off the work piece.
 - (8) Release the trigger switch and let the saw head moves up slowly.
 - (9) Turn the vise hand wheel 1/2 (half) turn counter-clockwise to release the work piece.
- Repeat step (2) through (9) to finish the job.

NOTE: Release the trigger switch immediately if any malfunction or abnormal situation happens.

5.3 Daily Inspection and Maintenance

5.3.1 Gear Box of Cutting Head

- (1) Change gear oil (SAE 140) every six months.
- (2) Check temperature of the gearbox during continuous operation.

5.3.2 Chip Collecting Tray

Remove chip from collecting tray everyday.

6. ELECTRICAL SYSTEM DIAGRAM

INDEX	
-------	--

PAGE	INDEX	DRAW NO.	TITLE	DESCRIPTION
1	0	11VB51B1	INDEX	
2	0	11VE52B1	SYSTEM BLOCK DIAGRAM	
3	0	11VB53B1	SYSTEM CONNECTED DIAGRAM	
4	1	11VB54B1	POWER CIRCUIT	POWER CIRCUIT DIAGRAM
5	2	11VB55B1	PARTS POSITION LAYOUT	POWER & CONTROL SYSTEM LAYOUT DIAGRAM
6	2	11VE56B1	PARTS POSITION LAYOUT	CONTROL PANEL LAYOUT DIAGRAM
7	3	11VB57B1	PARTS LIST	PARTS LIST TABLE

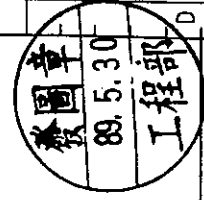

APPROVED 工程師 89.5.30 謝坤旺	CHECKED 謝坤旺 89.5.30	DRAWN 鄧陽志 89.5.30		No. 11VB51B1 = Title + MC315F INDEX Scale 1:1 Edit 1 Index 0 Page 1
-----------------------------------	---------------------------	-------------------------	--	--

MACHINERY HOUSE

SYSTEM BLOCK DIAGRAM

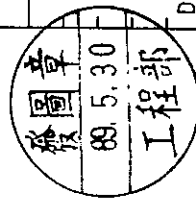
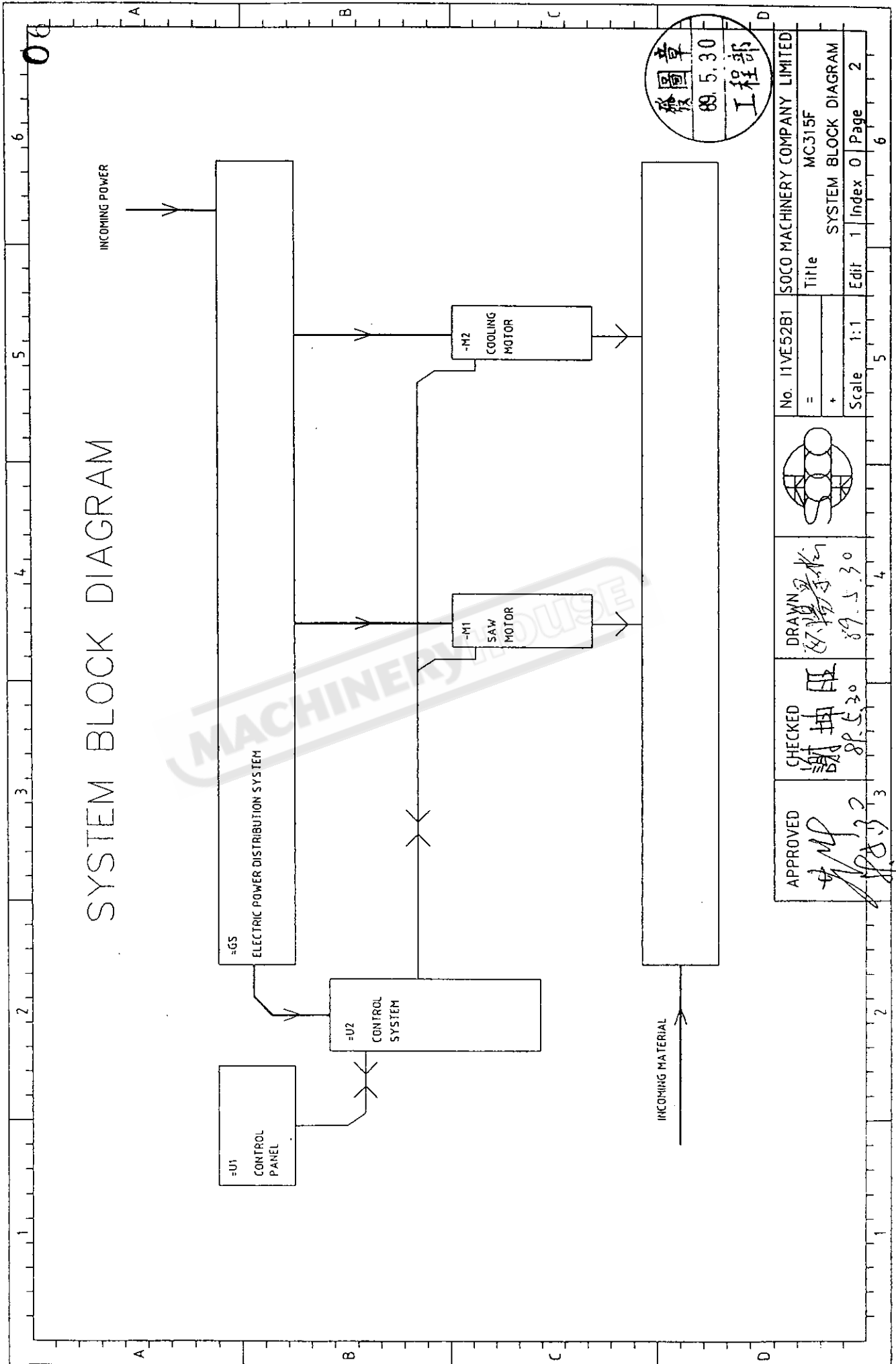

APPROVED	CHECKED	DRAWN	No. 11VE52B1	SOCO MACHINERY COMPANY LIMITED	
				Title	MC315F
			Scale	1:1	Index
			Edit	1	Page
				0	2
				5	6

SYSTEM CONNECTED DIAGRAM

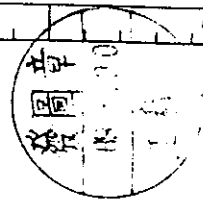
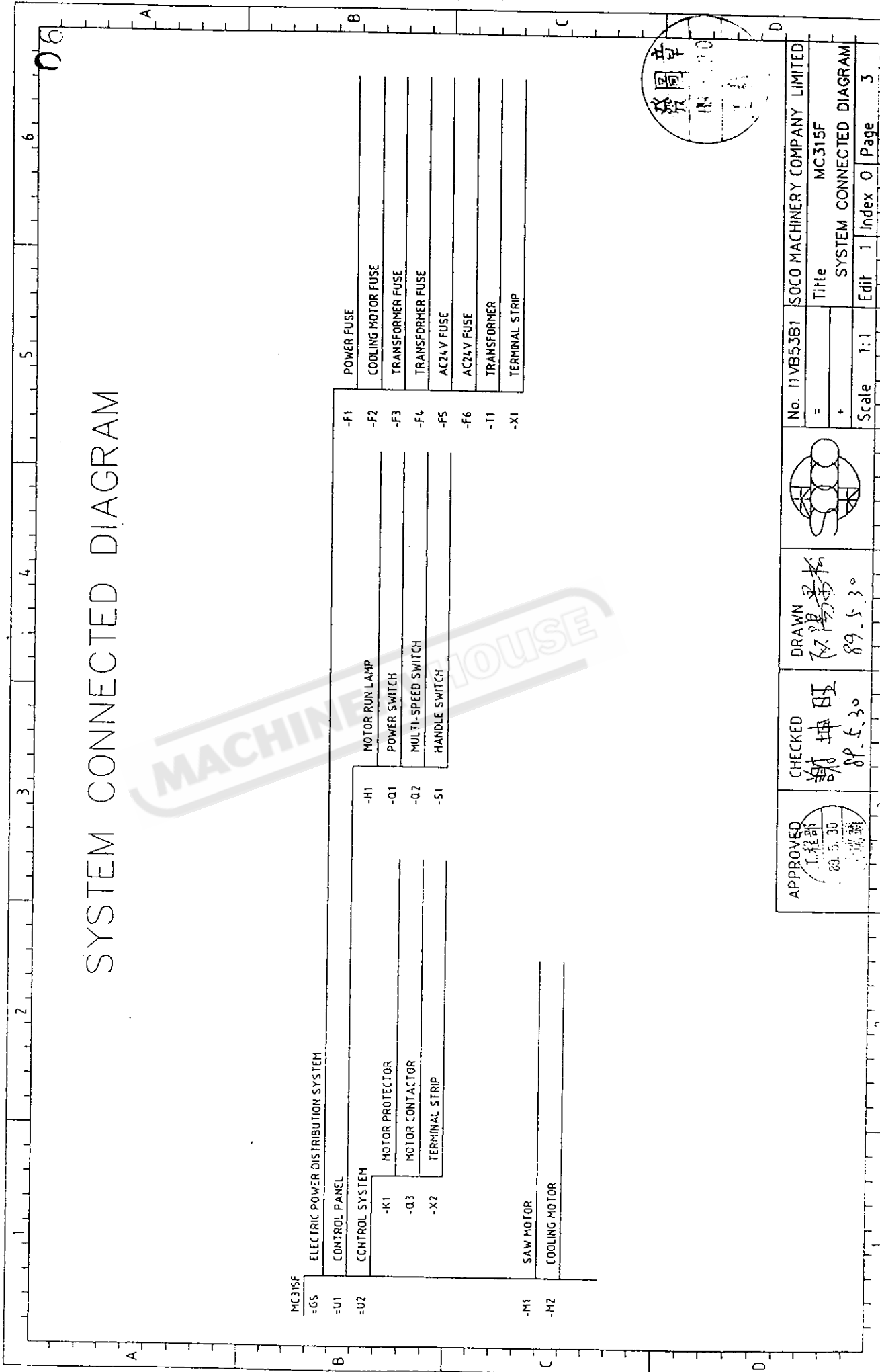

APPROVED 工程師 89.5.30 [Signature]	CHECKED 謝坤旺 89.5.30	DRAWN 張陽志 89.5.30		No. 11VB53B1 =	SOCO MACHINERY COMPANY LIMITED
				+	Title MC315F
					SYSTEM CONNECTED DIAGRAM
				Scale 1:1	Edit 1 Index 0 Page 3

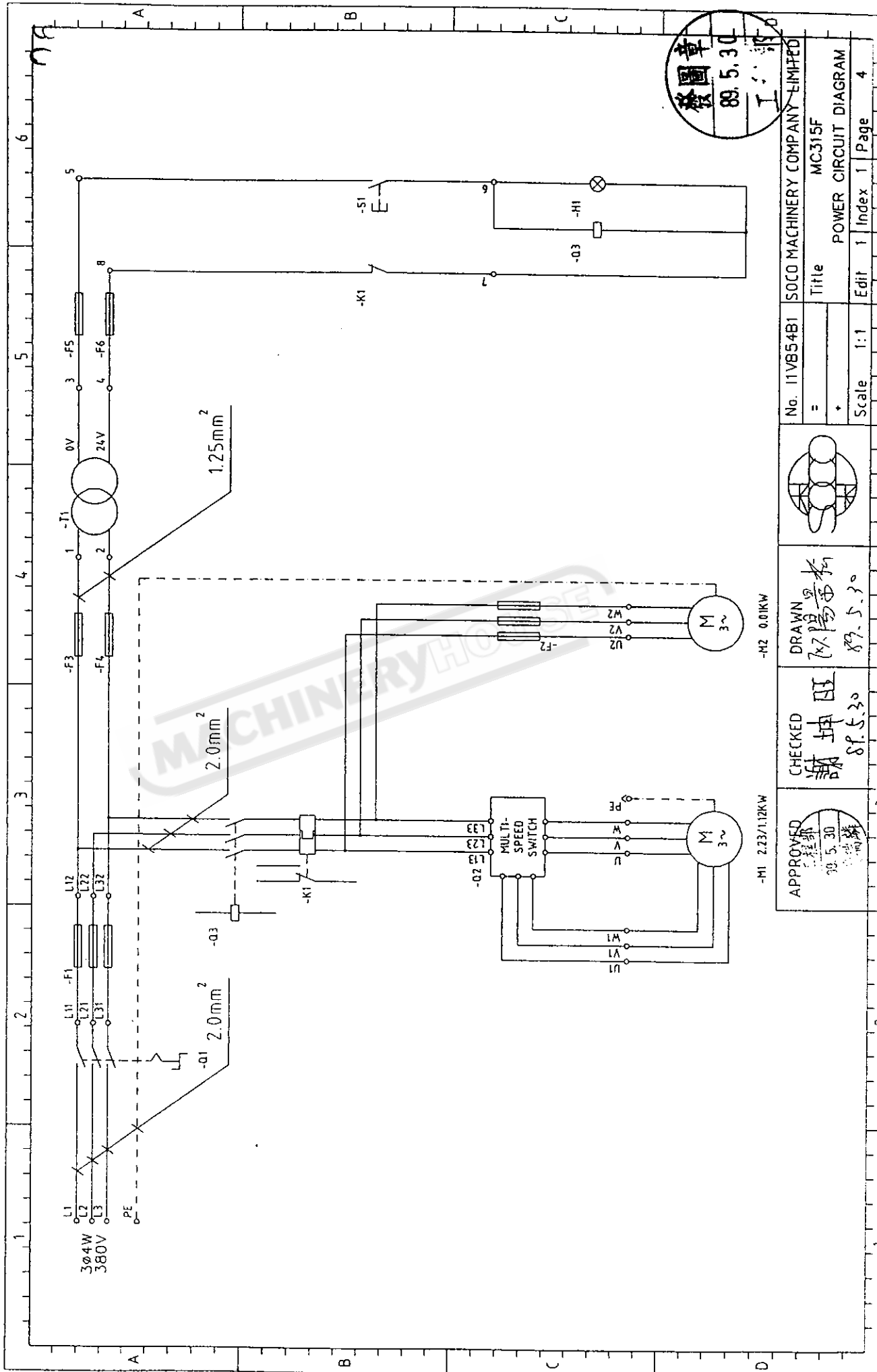

No. 11VB54B1	SOCO MACHINERY COMPANY LIMITED	
=	Title	MC315F
+	POWER CIRCUIT DIAGRAM	
Scale 1:1	Edit 1	Index 1
	Page 1	Page 4

APPROVED
 89.5.30
 89.5.30

CHECKED
 89.5.30

DRAWN
 89.5.30

MACHINERY COMPANY LIMITED



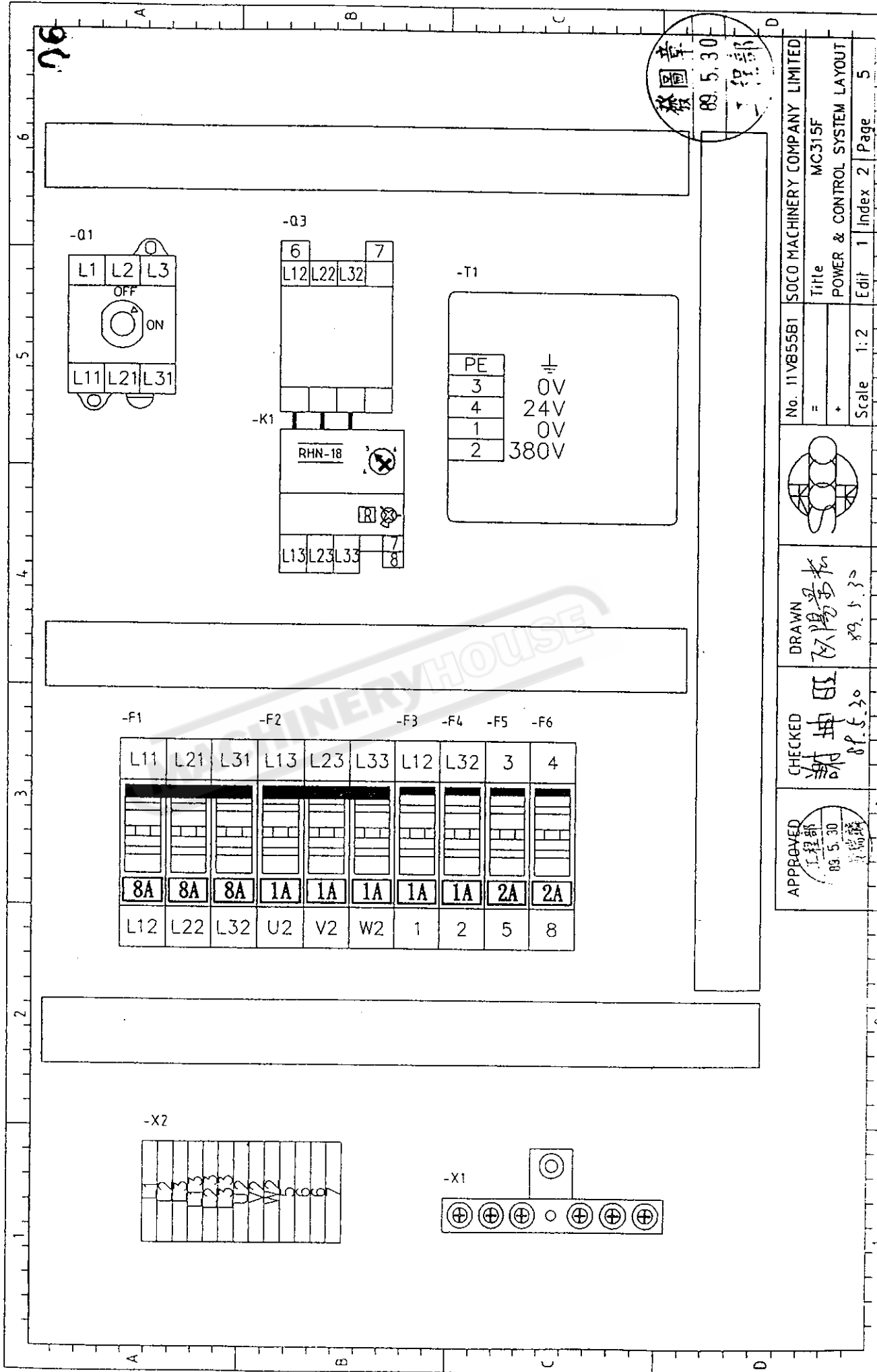

89.5.30
 工程圖章
 工程圖章

No. 11VB55B1	SOCO MACHINERY COMPANY LIMITED
Title	MC315F
+	POWER & CONTROL SYSTEM LAYOUT
Scale 1:2	Edit 1 Index 2 Page 5
CHECKED	謝坤 89.5.30
DRAWN	歐陽芳松 89.5.30
APPROVED	工程圖章 89.5.30

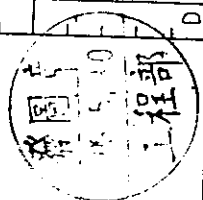
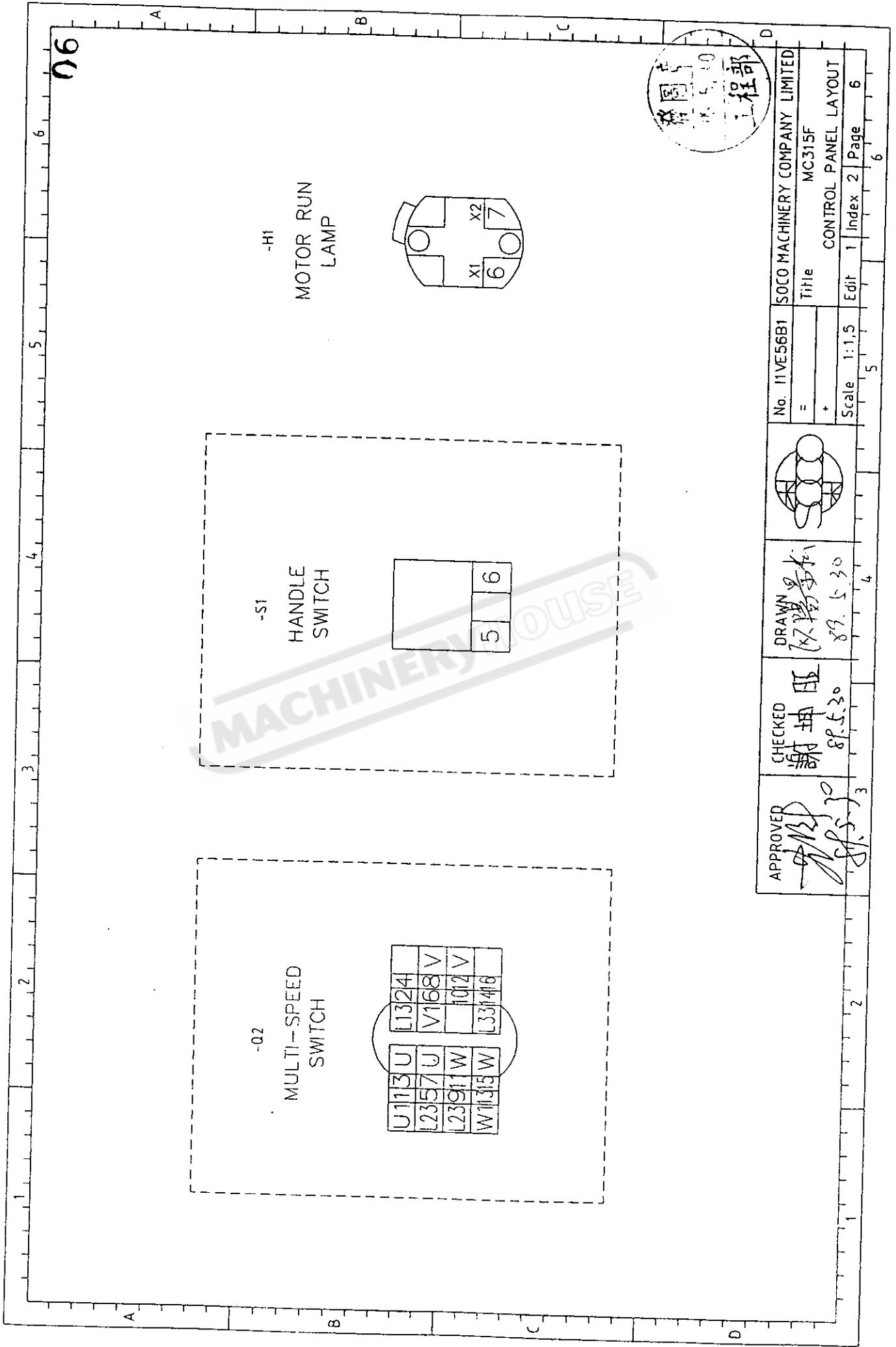

MACHINERY HOUSE

06

PARTS LIST (380V)

ITEM	LOCATION	DESCRIPTION	TYPE	QTY
-F1	=GS	FUSE(保險絲附一只3P保險絲座)	10.3X38(AM)8A	3
-F2	=GS	FUSE(保險絲附一只3P保險絲座)	10.3X38(AM)1A	3
-F3	=GS	FUSE(保險絲附座)	10.3X38(GL)1A	1
-F4	=GS	FUSE(保險絲附座)	10.3X38(GL)1A	1
-F5	=GS	FUSE(保險絲附座)	10.3X38(GL)2A	1
-F6	=GS	FUSE(保險絲附座)	10.3X38(GL)2A	1
-T1	=GS	TRANSFORMER(變壓器)	1ø,380V/24V,50VA	1
-X1	=GS	TERMINAL STRIP(端子座)	TB-6	1
-H1	=U1	INDICATION LAMP(指示燈)	24V,ø22,RED	1
-Q1	=U1	POWER SWITCH(門式開關)	KG10 K300/RCZ002/VE	1
-Q2	=U1	MULTI-SPEED SWITCH(變極開關)	CA10 A441 U50760/006SIS	1
-S1	=U1	HANDLE SWITCH(把手開關)		1
-K1	=U2	PROTECTOR(過載保護器)	RHN-18/6~9(6A)	1
-Q3	=U2	CONNECTOR(電磁接觸器)	AC24V,CN-16	1
-X2	=U2	TERMINAL STRIP(端子座)	SAK 2.5/EN	13
-M1		SAW MOTOR(馬達)	3ø,380V,2.23/1.12KW	1
-M2		COOLING MOTOR(水幫浦)	3ø,415V,0.01KW	1



APPROVED 工程師 89.5.30 張福祥	CHECKED 謝坤旺 89.5.30	DRAWN 張揚景松 89.5.30		No. 11VB57B1	SOCO MACHINERY COMPANY LIMITED
				Title	MC315F
				Scale 1:1	Index 3
				Edil 1	Page 7

Chapter 8 Parts Lists And Drawings

No.01	Head And Spindle Shaft Assembly	15
No.02	Motor Assembly	17
No.03	Feed Handle Assembly	19
No.04	Rotary Support Assembly	21
No.05	Vise Assembly	23
No.06	Table Assembly	25
No.07	Safety Guard Assembly	27
No.08	Main Base Assembly	29
No.09	Small Base Assembly	31
No.10	Electric Circuit	33

NO.	PART NO.	MAT.NO.	DESCRIPTION	QTY.	SPECIFICATION	NO.	PART NO.	MAT.NO.	DESCRIPTION	QTY.	SPECIFICATION
1	13A011		HEAD STOCK	1	FC25	25	M3C004		SPACER	1	SS41
2	13A010		COVER	1	SS41	26	M3C007		THRUST BEARING	1	E30305J
3	13C010		WORM WHEEL	1	ALBC3	27	M3C005		COVER	1	SS41
4				1	SS41	28	F06D016		SCREW	4	M6XP1.0X16
5	VG0023		BEARING	1	E30309J	29	M3C011		HELICAL GEAR	1	S45C
6	ZQ0065		OIL SEAL	1	55X72X9 TC	30	M0C034		CHECK NUT	1	S45C
7	13A014		BEARING COVER	1	S45C	31	13A004		ADJUSTABLE NUT	1	SS41
8	F06D016		SCREW	3	M6XP1.0X16	32	F10F060		SCREW	1	M10XP1.0X60
9	ZV0029		KEY	1	8X7X28	33	13A006		ARM	1	SS41
10	13C01204		SPINDLE SHAFT	1	SCM21	34	13A008		SPRING	1	SUP6
11	H0C012		PIN	2	D10XL28	35	R10		SPRING WASHER	1	M10
12	H0C001		BLADE COVER	1	S45C	36	F10F025		SCREW	2	M10XP1.5X25
13	Q10		FLAT WASHER	1	M10	37	G08E025		SCREW	2	M8XP1.25X25
14	F10G035		SCREW	1	M10XP1.5X35(1.25F)	38	M08E		HEX NUT	2	M8
15	VG0030		BEARING	1	E32207J	39	M3C009		OUTER TOOTH WASHER	1	AW05
16	H0C006		HEX NUT	1	M30XP1.5	40	M3C010		CHECK NUT	1	AN05
17	C155		OUTER TOOTH WASHER	1	M30	41	VF0018		NEEDLE BEARING	1	TLA 253226
18	13A013		COVER	1	SS41	42	F04B012		SCREW	3	M4-12
19	F06D016		SCREW	3	M6XP1.0X16	43	ZK0165		CHECK NUT	1	YSF M40XP1.5
20	IK0031		SIGHT GLASS	1	21mm	44	I3C01400		SPACER	1	SS41
21	ZE0010		DRAIN PLUG	1	PT3/8"XL12,PLUG	45					
22						46					
23	13C011		WORM SHAFT	1	SNCM220	47					
24	M3C008		THRUST BEARING	1	E30205J	48					

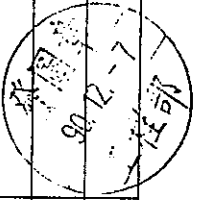

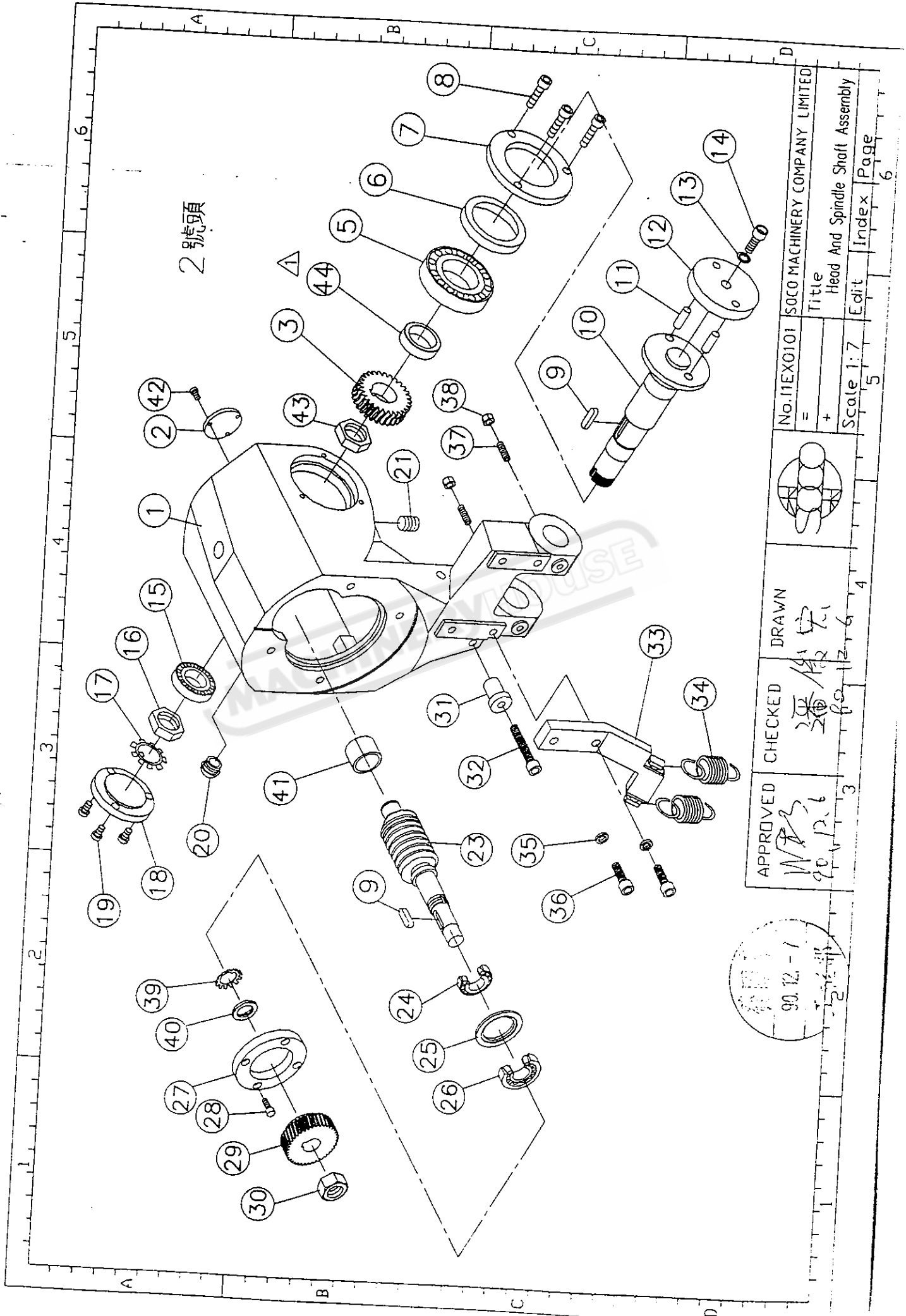

APPROVED WFS 2012.6	CHECKED 潘安 2012.6	DRAWN 潘安 2012.6	No. I1EX0101 = +	SOLO MACHINERY COMPANY LIMITED	
				Title Head And Spindle Shaft Assembly	Page 6
Scale 1:7			Edit	Index	Page
			5		6

90.12-1
2012.6

NO.	PART NO.	MAT. NO.	DESCRIPTION	QT.	SPECIFICATION	NO.	PART NO.	MAT. NO.	DESCRIPTION	QT.	SPECIFICATION
1	I3B002		MOTOR ASSEMBLY	1	3/1.5HP 2/4 P	25					
2	H0G001		MOTOR ELECTRIC BOX	1	SS4I	26					
3	ZR0020		CLAMPER	1	7C	27					
4	H0G002		FIXING PLATE	1	SPCC	28					
5	XC0066		TERMINAL BOARD	1	6P20A	29					
6	B04B006		SCREW	4	M4xP0.7x6	30					
7	F06D025		SCREW	2	M6xP1.0x25	31					
8	H0G003		COVER	1	SS4I	32					
9	B06D020		SCREW	4	M6xP1.0x20	33					
10	R06		SPRING WASHER	4	M6	34					
11	WS0031		MULTI SPEED	1	SC6848(20A)	35					
12	ZR0019		CLAMPER	1	4C	36					
13	ZV0040		KEY	1	6x6x30	37					
14	I3C009		HELICAL GEAR	1	SNCM22	38					
15	B15		OUTER TOOTH WASHER	1	M20	39					
16	M20F		HEX NUT	1	M20XP1.5	40					
17						41					
18						42					
19						43					
20						44					
21						45					
22						46					
23						47					
24						48					

06

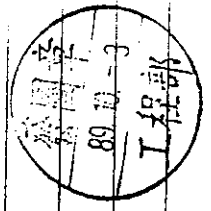

FOR HEAD NO.2

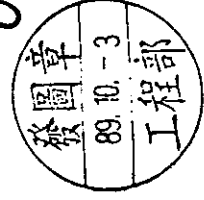
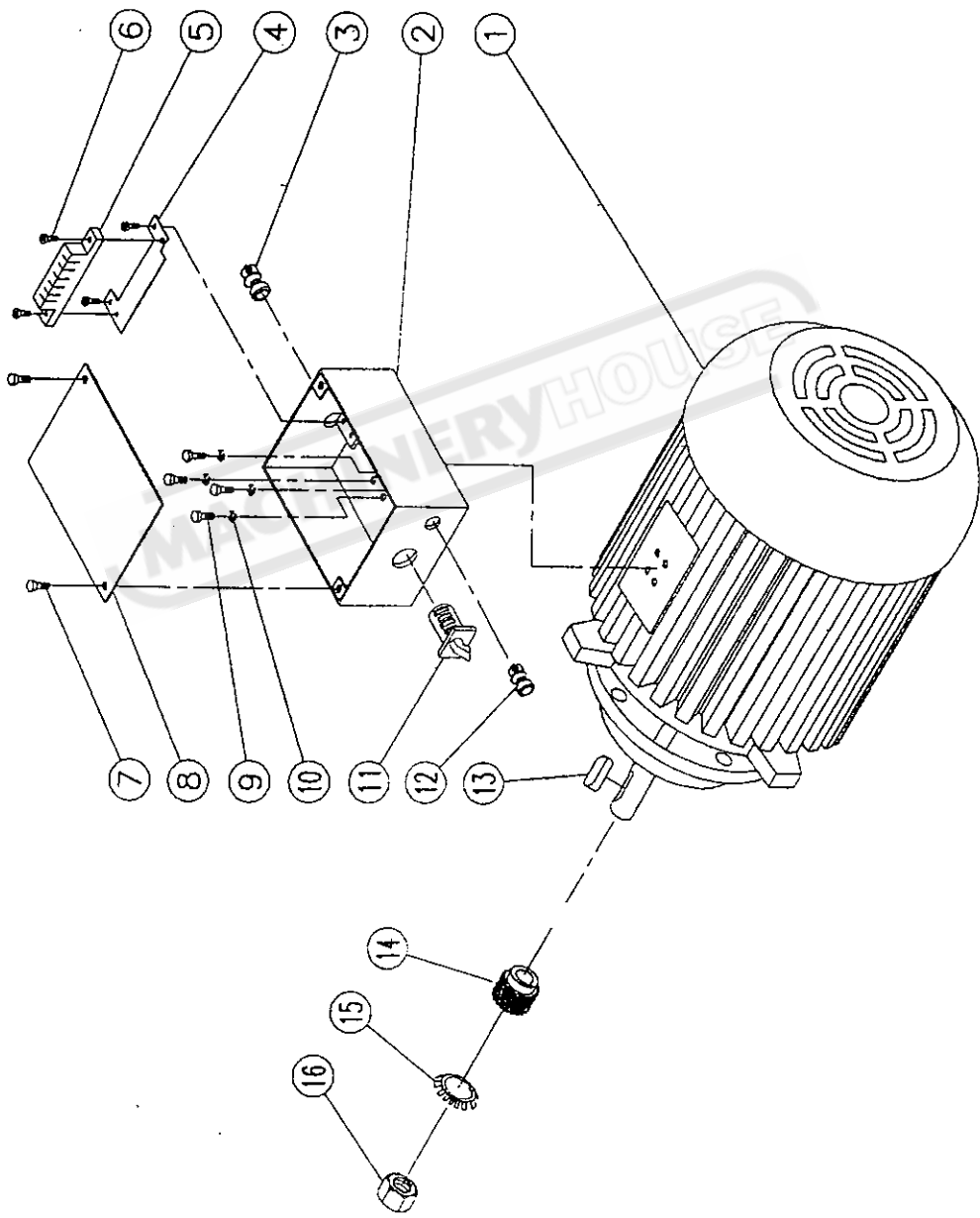

APPROVED <i>[Signature]</i>	CHECKED <i>[Signature]</i>	DRAWN <i>[Signature]</i>	No. 11EX0200	SOCO MACHINERY COMPANY LIMITED		
				Title Motor Assembly		
Scale 1:1			Edit	Index	Page	
			5		6	

***** MC-315F *****

11EX0300

No.	PART NO.	MAT.NO.	DESCRIPTION	QT.	SPECIFICATION	NO.	PART NO.	MAT.NO.	DESCRIPTION	QT.	SPECIFICATION
1	XA0061		CABLE	1	4CX0.75MM	25					
2	XE0010		RUBBER SLEEVE	1	SMALL	26					
3	B04B028		SCREW	4	M4XP0.7X28	27					
4	H0A003		FEED LEVER KNOB	1	PLASTIC(ABS)	28					
5	B04B028		SCREW	1	M4XP0.7X28	29					
6	H0A004		RUBBER SHIELD	1	RUBBER	30					
7	H0A028		ELECTRIC SWITCH	1	SS41	31					
8	H0A006		FEED LEVER KNOB	1	PLASTIC(ABS)	32					
9	M04C		HEX NUT	5	M4XP0.7	33					
10	H0A007		FEED LEVER	1	SS41	34					
11	M20K		HEX NUT	1	M20XP2.5	35					
12	I3A003		PIVOT SHAFT	2	S45C	36					
13	I3A005		JUNK RING	2	SS41	37					
14	I3A009		SPLASH SHIELD	1	PLASTIC	38					
15	M30F		CHECK NUT	2	M30XP1.5	39					
16	Q08		WASHER	2	M8	40					
17	C08E012		SCREW	1	M8XP1.25X12	41					
18						42					
19						43					
20						44					
21						45					
22						46					
23						47					
24						48					

06

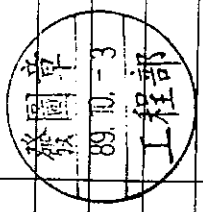

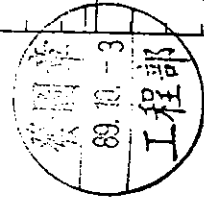
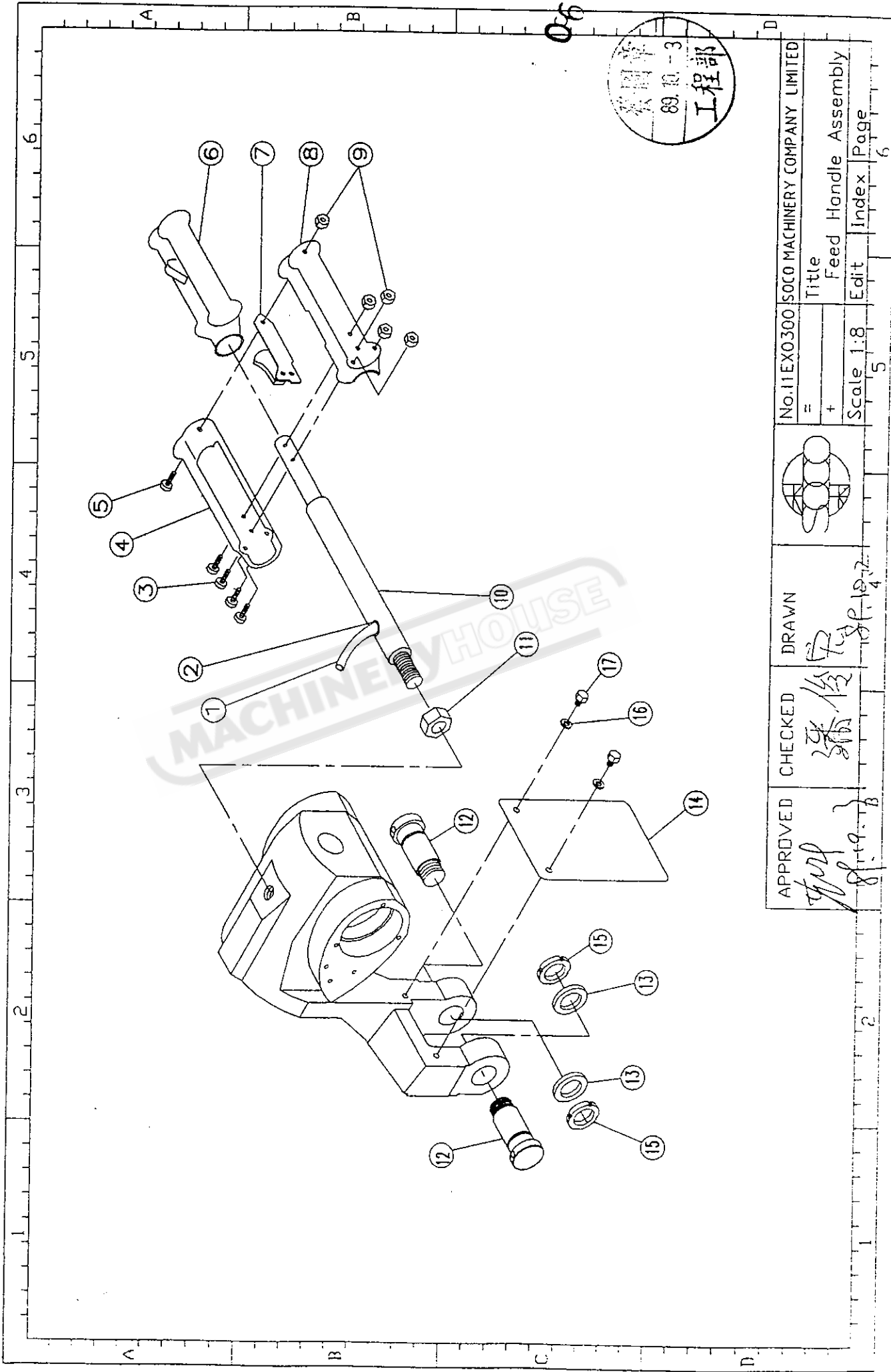

APPROVED <i>[Signature]</i>	CHECKED <i>[Signature]</i>	DRAWN <i>[Signature]</i>	No. I1EX0300 SOCO MACHINERY COMPANY LIMITED	Title	
				Feed Handle Assembly	Page 6
			Scale 1:8	Edit	Index
			5		6

***** MC-315F *****

11EX0400

NO.	PART NO.	MAT.NO.	DESCRIPTION	QT.	SPECIFICATION	NO.	PART NO.	MAT.NO.	DESCRIPTION	QT.	SPECIFICATION
1	I3D00101		VISE BODY	1	FC25	25					
2	H5D00200		BOTTOM SHIELD	1	SPCC	26					
3	H0D003		PRESS BLOCK	1	FC25	27					
4	H5D00400		PACKING-UP	1	S45C	28					06
5	F08E035		SCREW	2	M8XP1.25X35	29					
6	F06D030		SCREW	2	M6XP1.0X30	30					
7	H5D00500		PACKING-UP	1	S45C	31					
8	H0C012		PIN	2	D10X1.28	32					
9	A06D030		RIVET	2	M6xP1.0x30	33					
10	H0C012		PACKING-UP	1	S45C	34					
11	H5D00600		FIXING SCREW	1	S45C	35					
12	H0D007		SPACER	1	SS41	36					
13	M08E		HEX NUT	3	M8XP1.25	37					
14	G08E040		SCREW	3	M8XP1.25X40	38					
15	H0D008		LOCKING BLOCK	1	FC20	39					
16	H0A014		FIXING LEVER	1	SS41	40					
17	H0A029		KNOB	1	PLASTIC	41					
18	I3A00204		ROTARY SUPPORT	1	FC25	42					
19	ZK0293		GREASE NIPPLE	2	PT1/8"	43					
20	I3A007		ARM	1	SS41	44					
21	R10		SPRING WASHER	2	M10	45					
22	F10F025		SCREW	2	M10XP1.5X25	46					
23	I3F013		BRACKET	1	SS41	47					
24						48					

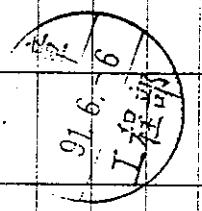

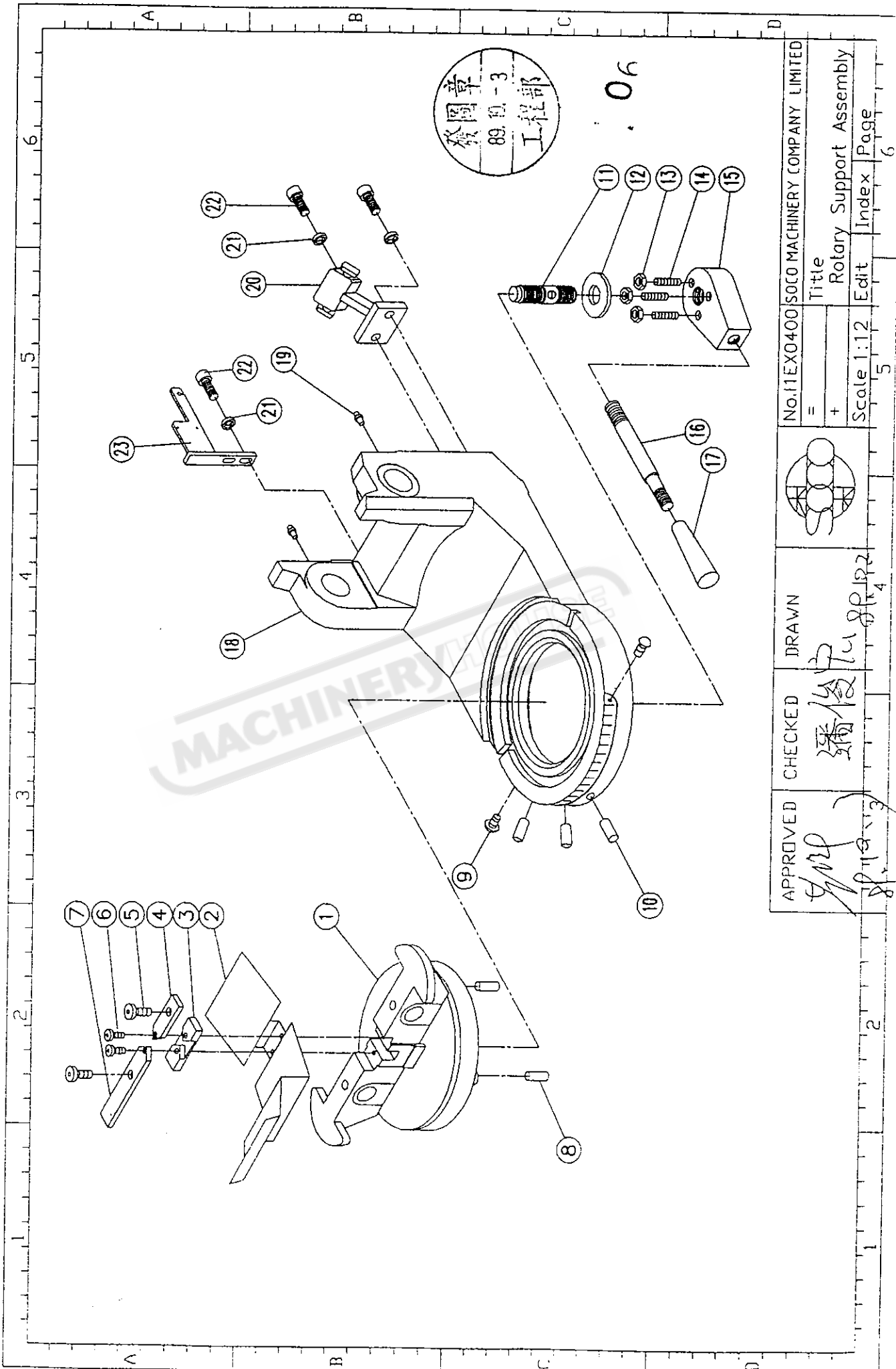

APPROVED <i>[Signature]</i>	CHECKED <i>[Signature]</i>	DRAWN <i>[Signature]</i>	No.11EX0400	ISOCO MACHINERY COMPANY LIMITED		
				Title Rotary Support Assembly		
Scale 1:12			Edit	Index	Page	
			5		6	

***** MC-315F *****

11EX0500

NO.	PART NO.	MAT.NO.	DESCRIPTION	QT.	SPECIFICATION	NO.	PART NO.	MAT.NO.	DESCRIPTION	QT.	SPECIFICATION
1	H5D00100		SCREW SHAFT	1	S45C	25					
2	H0D010		FRONT NUT	1	S45C	26					
3	F10F035		SCREW	4	M10XP1.5X35	27					
4	H5D00700		WISE	2	FC20	28					
5	ZQ0057		OIL SEAL	4	CV28405	29					
6	H5D00800		CLAMP KIT	2	SS41	30					
7	H5D00900		RAIL SHAFT	2	S45C	31					
8	H5D01100		CLAMP KIT	2	SS41	32					
9	H0D015		REAR NUT	1	FC25	33					
10	M10F		NUT	4	M10XP1.5	34					
11	C08E035		SCREW	2	M8XP1.25X35	35					
12	H0A017		RULLER FINGER	1	SUS304	36					
13	B03A005		SCREW	2	M3XP0.5X5	37					
14	H0D016		HANDLE SOCKET	1	FC25	38					
15	ZK0200		SPRING PIN	1	D6X40	39					
16	M12G		NUT	3	M12XP1.75	40					
17	H0D017		CLAMP LEVER	3	SS41	41					
18	ZK0033		KNOB	3	1/2" BALL	42					
19						43					
20						44					
21						45					
22						46					
23						47					
24						48					

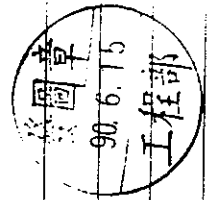

06

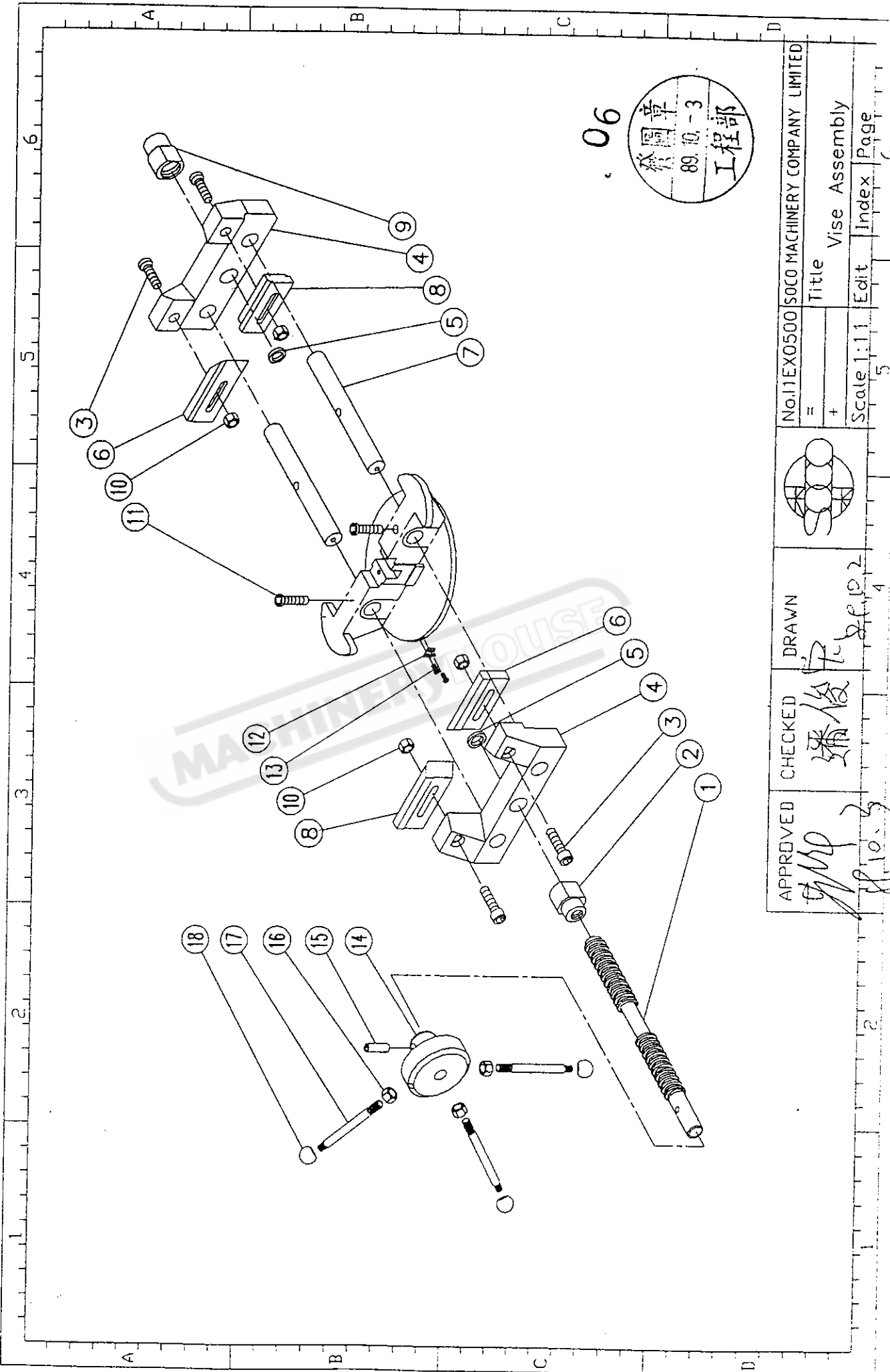

06
 發圖章
 89.10.-3
 工程部

MACHINE HOUSE

APPROVED	CHECKED	DRAWN	No.11EX0500	SOCO MACHINERY COMPANY LIMITED	
				=	Title
8.10.3	潘俊	8.10.2	5	Vise Assembly	
				Scale 1:11	Edit
			5	Index	Page

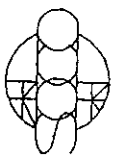

***** MC-315F *****

NO.	PART NO.	MAT.NO.	DESCRIPTION	QT.	SPECIFICATION	NO.	PART NO.	MAT.NO.	DESCRIPTION	QT.	SPECIFICATION
1	H5A00200		TABLE	1	FC20	25					
2	I3A01601		LOCKING PLATE	1	S45C	26					
3	ZK0275		PIN	1	D10XL30	27					
4	I3A01501		ANGLE FIXING ASS'Y BODY	1	FC25	28					
5	Q08		FLAT WASHER	2	M8	29					
6	M08E055		SCREW	2	M8XP1.25X55	30					
7	H5A00600		OIL FILTER	1	MESHES	31					
8	H0A021		WASHER	3	S45C	32					
9	R10		SPRING WASHER	3	M10	33					
10	E10F050		SCREW	3	M10XP1.5X50	34					
11	M08E		HEX NUT	1	M8	35					
12	F08E030		SCREW	1	M8XP1.25X30	36					
13	ZK0023		HOOK	4	12M/M	37					
14						38					
15						39					
16						40					
17						41					
18						42					
19						43					
20						44					
21						45					
22						46					
23						47					
24						48					

06

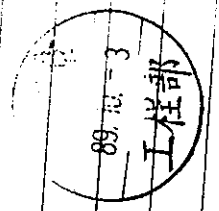

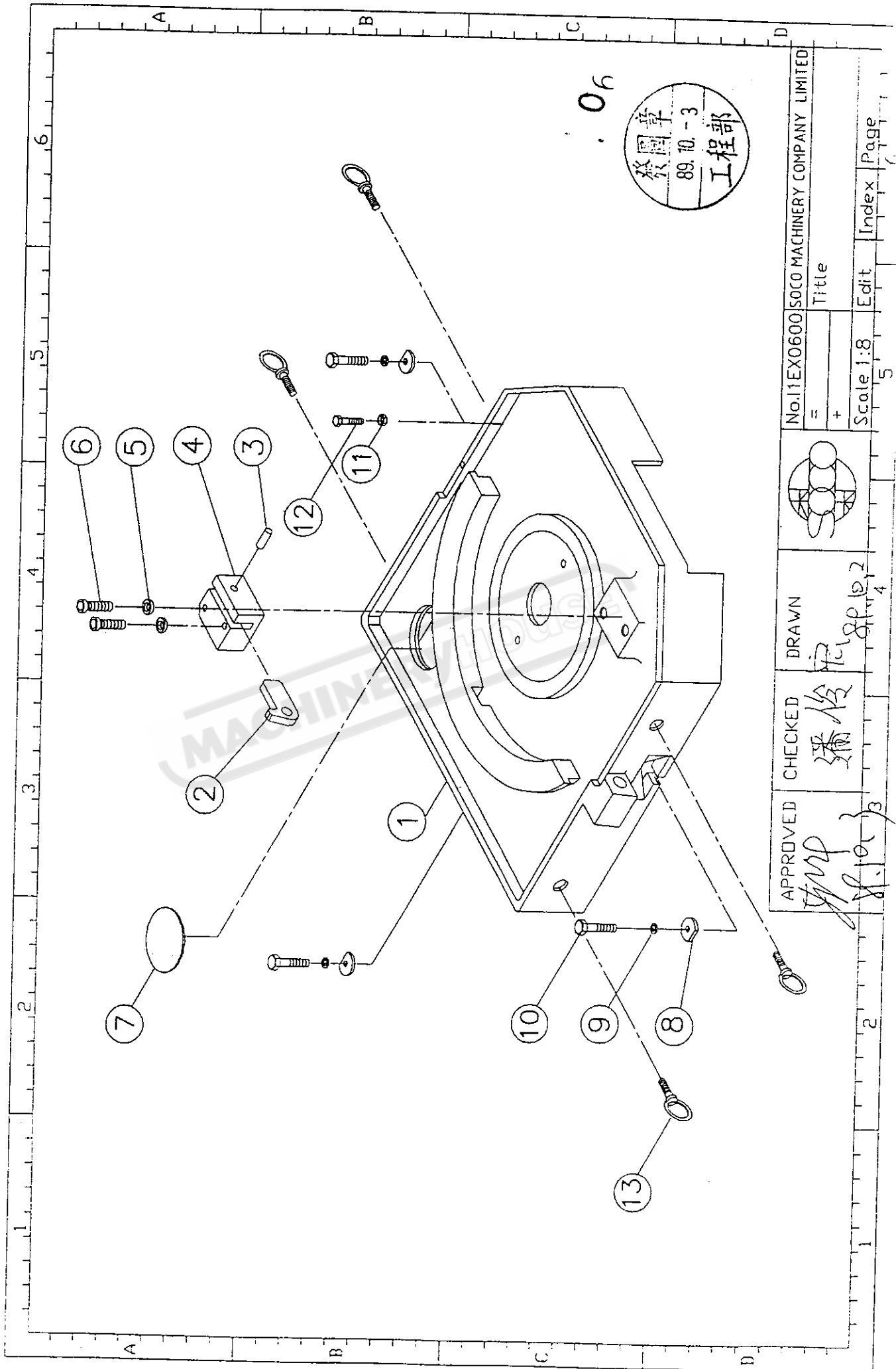

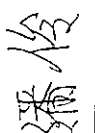
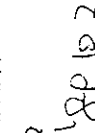
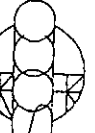
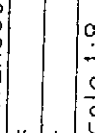
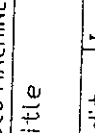
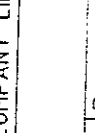
APPROVED	CHECKED	DRAWN	No. I1EX0600	SOCO MACHINERY COMPANY LIMITED	
				=	+
			Title		
			Scale 1:8		
			Edit		
			Index		
			Page		
			5		

***** MC-315F *****

11EX0700

NO.	PART NO.	MAT.NO.	DESCRIPTION	QT.	SPECIFICATION	NO.	PART NO.	MAT.NO.	DESCRIPTION	QT.	SPECIFICATION
1	I3F01904		SAFETY GUARD	1	FC25	25	ZK0289		STEEL WHEEL	1	φ 38
2	M08E		NUT	1	M8XP1.25	26	ZP0017		C RING	1	S-10
3	IC0058		WATER HOSE	1	3/8" - 150cm	27	I3F02000		ADJUST BAR	1	SS41
4	ZR0016		HORSE CLAMPER	1	15mm	28	I3F02101		COVER	1	SS41
5	IB0150		CONTROL VALVE	1	PT1/8" - W3/8"	29					
6	GK0190		ELBOW	1	M8-PT1/8" - 90°	30					
7	I3F00101		SHIELD	1	AC4C	31					
8	I3F004		SCREW	1	SS41	32					
9	M10F		HEX NUT	2	M10	33					
10	F10F016		SCREW	2	M10XP1.5X16	34					
11	Q10F		SPRING WASHER	2	M10	35					
12	I3F016		LEVER	1	SPPC	36					
13	I3F017		LEVER	1	SPPC	37					
14	F10F020		SCREW	2	M10XP1.5X20	38					
15	I3F018		LEVER	1	STEEL ROPE	39					
16	F06D016		SCREW	3	M6XP1.0X16	40					
17	F08E030		SCREW	2	M8XP1.25X30	41					
18	M05C		HEX NUT	1	M5XP0.8	42					
19	F05C016		SCREW	1	M5XP0.8X16	43					
20	F06D020		SCREW	2	M6XP1.0X20	44					
21	Q06		FLAT WASHER	2	M6	45					
22	R08		SPRING WASHER	2	M8	46					
23	Q08		FLAT WASHER	2	M8	47					
24	ZK0275		PIN	1	φ 10X30L	48					

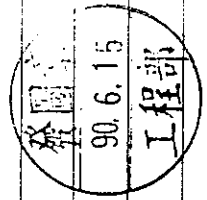

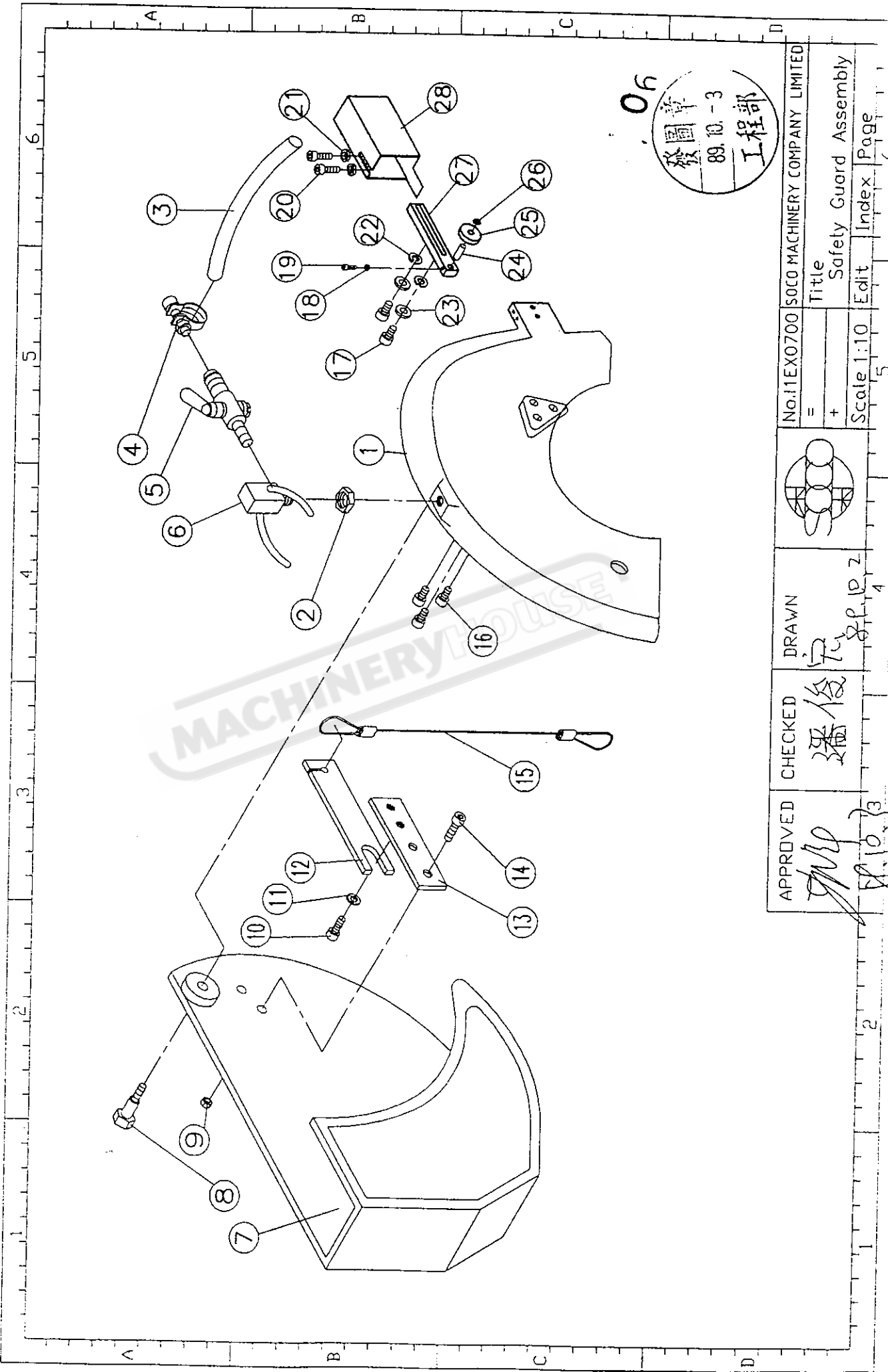

06
 發圖章
 89.10.-3
 工程部

MACHINERY HOUSE

APPROVED	CHECKED	DRAWN	No.11EX0700	SOCO MACHINERY COMPANY LIMITED
<i>[Signature]</i>	潘俊	潘俊	=	Title
			+	Safety Guard Assembly
			Scale 1:10	Edit
			5	Index
				Page

NO.	PART NO.	MAT.NO.	DESCRIPTION	QT.	SPECIFICATION	NO.	PART NO.	MAT.NO.	DESCRIPTION	QT.	SPECIFICATION
1	H5H00200		BASE	1	SPCC	25					
2	H0H002		ELECTRIC BOX	1	SS41	26					
3	Q05		FLAT WASHER	4	M5	27					
4	B05C010		SCREW	4	M5XPO.8X10	28					
5	WS0068		MAGNETIC CONTACTOR	1	CN-16, AC24V	29					
6	WA0034		TRANSFORMER	1	220, 380, 415, 440V/19, 24V, 40VA	30					
7	H0H003		LID	1	SS41	31					
8	ZR0020		CLAMPER	2	7C	32					
9	ZR0019		CLAMPER	1	4C	33					
10	ZG0028		QUICK JOINT	2	SPL6-01	34					
11	E06D025		SCREW	8	M6XP1.0X25	35					
12	IC0236		PU HOSE	1	4X6	36					
13	F08E025		SCREW	2	M8XP1.25X25	37					
14	IC0058		WATER HOSE	1	3/8"-150mm	38					
15	ZR0017		HOSE CLAMPER	1	15mm	39					
16	ZA0010		JOINT COPPER	1	3/8IN-3/8OUT	40					
17	YB0019		CHECK VALVE	1	PT3/8	41					
18	ZN0031		JOINT	1	PT3/8OUT-PT3/8IN						
19	YF0015		PUMP	1	1/8HP-150L						
20	XA0061		CABLE	1	4CX0.75mm-700L						
21			OVER RELAY	1							
22											
23											
24											

06
發圖章
89.10.3
工程部

3/1.5HP
1.4/1HP
RHN-10M(5.5~8.5)
RHN-10M(3.5~5)
RHN-10M(3.5~5)
RHN-10M(3.5~5)
220V
380V
415V
440V
RHN-10M(8.5~12.5)
RHN-10M(5.5~8.5)
RHN-10M(5.5~8.5)
RHN-10M(5.5~8.5)

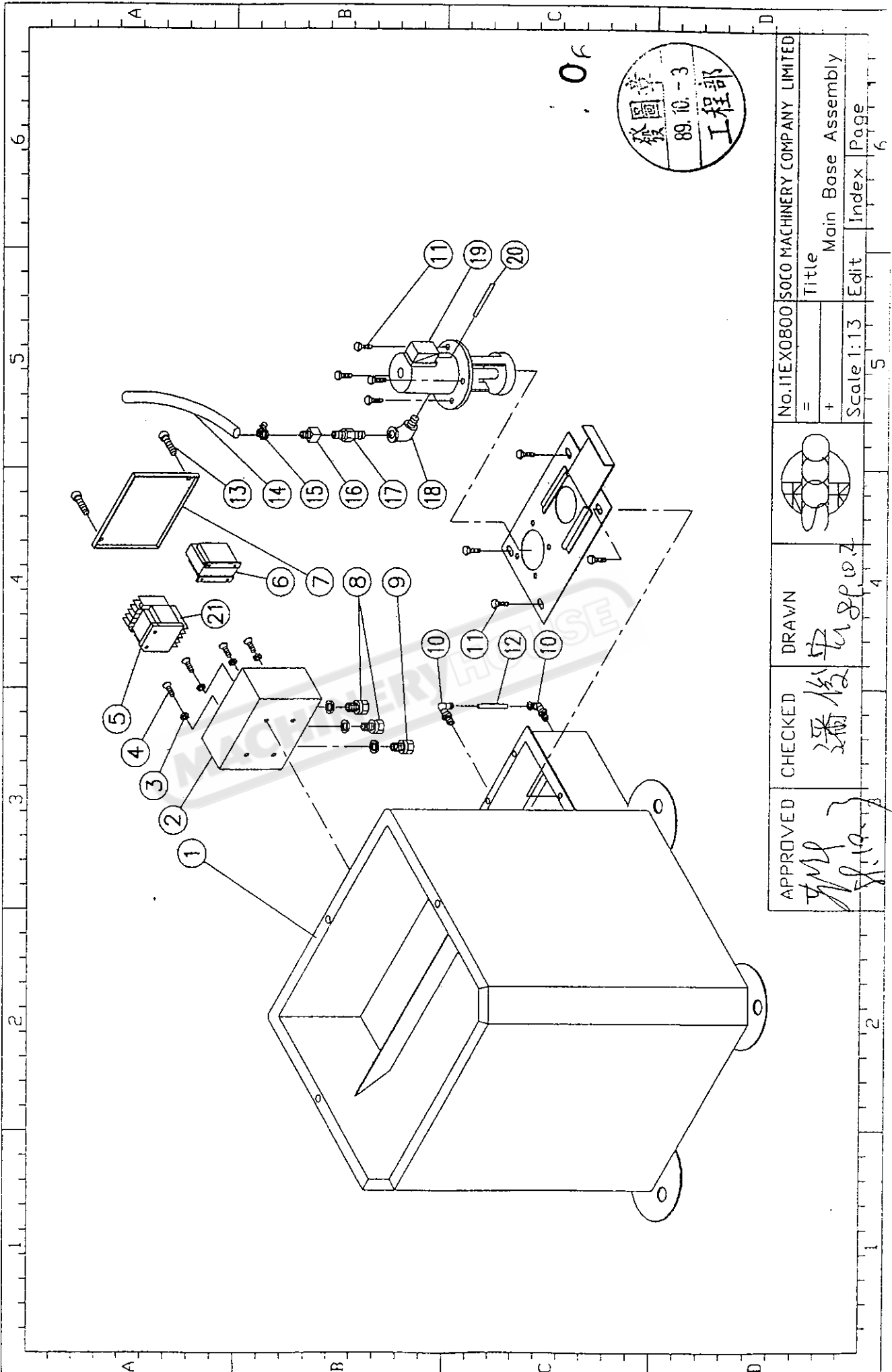

APPROVED	CHECKED	DRAWN	No. I1EX0800	SOCO MACHINERY COMPANY LIMITED	
				=	Title
[Signature]	[Signature]	[Signature]	Scale 1:13	Main Base Assembly	
				Edit	Page
			5	Index	6